

# HBD/Thermoid, Inc.

SUBSIDIARY OF **HBD** INDUSTRIES, INC.

# Thermoid

Effective: June 6, 2011

*Supersedes all previous price pages*

## **FLEXIBLE DUCTING PRODUCTS**

### **Industrial Ducting Distributor Price Pages**

#### **TOLL-FREE TELEPHONE NUMBERS**

**800/835-0682—Chanute Customer Service**

**800/543-8070—Bellefontaine Customer Service**

**800/362-3101—Ohio Only**

**800/421-6067—Belle Gardens, California Warehouse**

**620/431-9105—Fax—Chanute**

**800/423-4354—Fax—Bellefontaine**

**800/258-7654—Fax—Belle Gardens**

Freight—F.O.B. Shipping Point; No Freight Allowed.\*

Minimum Order—\$100.00 Net.

Payment Terms: Net 30 Days.

\*Prepaid freight on stock ducting items when included with an industrial hose order shipment of \$4000.  
Net (hose order value only) Continental U.S.A. only.

Product descriptions, specifications and pricing on products become dated and are subject to change. For questions concerning any current product pricing, technical and/or product application information contained in this publication, please contact HBD/Thermoid, Inc. Customer Service at 800/543-8070 and/or log onto [www.hbdthermoid.com](http://www.hbdthermoid.com).

## **HBD/Thermoid, Inc.**

SUBSIDIARY OF **HBD** INDUSTRIES, INC.



CHANUTE OPERATIONS  
201-211 N. Allen Avenue  
Chanute, KS 66720-0728  
620/431-9100

BELLEFONTAINE OPERATIONS  
1301 West Sandusky Avenue  
Bellefontaine, OH 43311-1082  
937/593-5010

WESTERN SALES OFFICE & WAREHOUSE  
8433 South Eastern Avenue, Unit A  
Belle Gardens, CA 90201  
562/776-9060

**[www.hbdthermoid.com](http://www.hbdthermoid.com) • [www.hbdindustries.com](http://www.hbdindustries.com)**

Email: [info@hbdthermoid.com](mailto:info@hbdthermoid.com)

**TABLE OF CONTENTS**



**ULTRAFLEX™**  
Page 3



**NEOFLEX®**  
Page 6



**FLEXKING®**  
Page 4

**FLEXKING® END FINISHES**  
Page 5



**TUFTEX®**  
Page 7

**DIP COATINGS AND ADDITIONAL  
RUBBER PLIES**  
Page 8



**SILFLEX®**  
Page 6



**CYCLONE®**  
Page 9

**CYCLONE® END FINISHES**  
Page 10

**STANDARD TOLERANCES**  
Page 11

**TERMS AND CONDITIONS OF SALE**  
Page 12

**ULTRAFLEX™ PVC/THERMOPLASTIC**

**TPU**  
Urethane

**TPR**  
Thermo-  
plastic Rbr  
(Black)

**TPC**  
Polyvinyl  
Chloride  
(PVC)  
(Blue)

**VP**  
Vinyl/Poly  
(Yellow  
w/wearstrip)  
(Price includes  
wearstrip on  
4" I.D. & above)

I.D. (in.)	TPU		TPR	TPC	Single Ply VP-1	Double Ply VP-2
	Black	Clear				
<b>2</b>	\$ 9.39*	\$ 9.65	\$ 4.06*	\$ 3.37	\$ 5.38	\$ 6.46
<b>2.5</b>	10.19	10.74	5.36*	4.27	5.51	6.65
<b>3</b>	11.00*	11.27*	6.00*	5.01*	5.61	6.77
<b>3.5</b>	11.89	12.25	7.11*	5.70*	6.05	7.34
<b>4</b>	12.61*	13.00*	7.65*	5.84*	6.15	7.41
<b>5</b>	14.63*	15.08*	8.13*	6.35	7.07	8.55
<b>6</b>	15.91*	16.81*	8.97*	6.94*	8.20	10.52
<b>7</b>	18.83	19.49	10.19*	8.23	8.35	10.80
<b>8</b>	19.74*	20.74*	11.49*	9.33*	9.24	12.24
<b>10</b>	28.77*	29.17*	14.70*	11.96	11.86	15.02
<b>12</b>	33.98*	—	17.63*	14.50	15.41	18.14
<b>14</b>	40.20	—	21.98	16.86	19.57	22.47
<b>16</b>	48.04	—	28.41	20.42	22.72	26.15
<b>18</b>	55.70	—	33.86	27.22	25.66	29.48

**\*STOCK ITEMS**

- A. Standard Lengths:** 25'-50' (25' stock length)
- B. For other than 25'-50':** add 10% to foot price.
- C. Type VP-1 and VP-2:** Wearstrip is standard on 4" I.D. and larger.
- D. Minimum Net Orders:** \$100.00

**THERMOID FLEXIBLE  
DUCTING PRODUCTS**
**INDUSTRIAL DUCTING**
**FLEXKING®**

TEMPERATURE RANGE -40°F to +250°F

**BASIC CONSTRUCTION CROSS SECTIONS**

SINGLE PLY FABRIC COATED WITH NEOPRENE

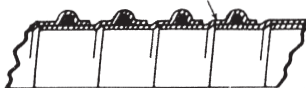

DOUBLE PLY RUBBER COATED FABRIC



PRICES ARE PER FOOT

SEE TECH. DATA CATALOG FOR COMPLETE ENGINEERING INFORMATION

I.D. (In.)	SINGLE PLY		DOUBLE PLY			CUFFS	DIP COATING
	SC	SE	DC	DE	DC-FR	Three Ply	Neoprene
	Neoprene Cotton/Poly	Neoprene Polyester	Neoprene Cotton/Poly	Neoprene Polyester	DC-Flame Retardant		
1½	\$ 5.07	\$ 5.55	\$ 6.10*	\$ 6.95	\$ 6.29	\$ 4.26	\$ 1.31
1¾	—	—	6.28*	7.40	6.46	4.26	1.31
2	5.93	6.26	6.74*	7.83	6.94	4.44	1.31
2¼	—	—	6.92*	8.30	7.11	4.63	1.31
2½	6.28*	7.00	7.17*	8.79	7.39	4.63	1.31
3	6.46*	7.60	7.71*	9.50	7.93	5.37	1.31
3½	7.03	7.91	8.32*	9.88	8.58	5.37	1.31
4	7.46*	8.22	8.58*	10.26	8.84	5.37	1.83
4½	7.70	8.79	9.40*	11.00	9.71	5.37	1.83
5	8.06	9.01	9.84*	11.79	10.13	6.03	1.83
5½	8.29	9.33	10.36	12.26	10.68	6.19	1.83
6	8.58*	9.73	10.64*	12.99	10.97	7.47	2.27
7	9.51	11.16	12.07*	14.89	12.44	8.70	2.45
8	10.48	12.16	13.47*	16.71	13.90	9.82	2.60
9	11.96	13.40	15.22	19.14	15.68	16.00	2.79
10	13.41	14.80	16.92*	21.17	17.42	19.49	2.79
12	15.89	19.27	20.46*	25.69	21.07	23.95	4.43
14	16.67	21.04	24.22*	30.08	24.93	35.49	4.43
16	—	—	28.04*	34.88	28.87	44.36	4.43
18	—	—	31.75*	39.50	32.79	51.47	4.43
20	—	—	41.59	48.72	42.86	70.31	6.26
22	—	—	46.53	54.27	47.95	76.16	6.26
24	—	—	51.99*	60.45	53.56	81.62	6.26

**\*STOCK ITEMS**

SPECIAL DIAMETERS AVAILABLE ON REQUEST.

**A. Standard Lengths:** 20'—25'—50', (25' Stock Length)

**Dip Coated Ducting:** 20' Feet (25 Ft. Lengths available on request).

**B.** All Standard Lengths of Ducting will be furnished with plain ends unless otherwise stated.

**C. For other than 20'—25'—50':** add 10% to foot price.

**D.** Refer to catalog for end finishes.

**E. Cuffs:** 1½" I.D.—5½" I.D. 1½" Length

6" I.D. and Over 2½" Length

Extra Plies—Add 20% to list price for each extra ply.

ALL ITEMS SUBJECT TO MINIMUM LINE CHARGE.

**SEE TERMS AND CONDITIONS—PAGE 12**

PRICES SUBJECT TO CHANGE WITHOUT NOTICE.

## INDUSTRIAL DUCTING

### FLEXKING®—END FINISHES

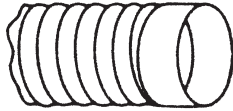

**Soft End**—That portion of the duct where the wire reinforcement is omitted, having the same number of plies as duct body, plus one additional ply of fabric over soft area. This type end provides a smooth clamping area.

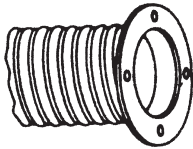

**Flanged End—Special\***—Airtight connections are made with flanged-end ducting. Flanges are manufactured in accordance with your engineering requirements. They may be made of metal, duct fabric or rubber-coated felt.

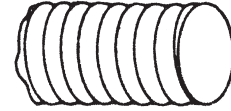

**Plain End**—Hose with a plain end is simply cut at a given point, the end being the same as the duct body. The wire at the cut end is crimped back to prevent snagging.

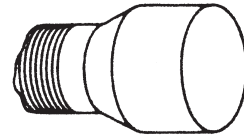

**Belled End—Special\***—A Belled End has a soft end with an I.D. larger than the duct body.

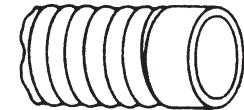

**Reduced End—Special\***—The hose end has an ID that is smaller than the duct body. A rubber insert usually forms this end.

*\*CUFFS: Wider and Heavier Cuffs are available.*

If **Longer Cuffs** are desired, add 10% to Soft End Price for each additional inch.

If **Heavier Cuffs** are desired add 20% for each additional ply desired.

**THERMOID FLEXIBLE DUCTING PRODUCTS**

**INDUSTRIAL DUCTING**

**SILFLEX®**

TEMPERATURE RANGE -80°F to +500°F INTERMITTENT TO 600°F

CROSS SECTION OF DUCT TYPES

**SILICONE**

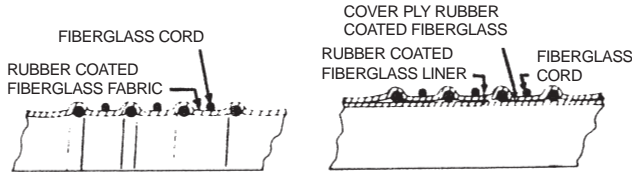

**NEOFLEX®**

TEMPERATURE RANGE -40°F to +350°F

CROSS SECTION OF DUCT TYPES

**NEOPRENE**

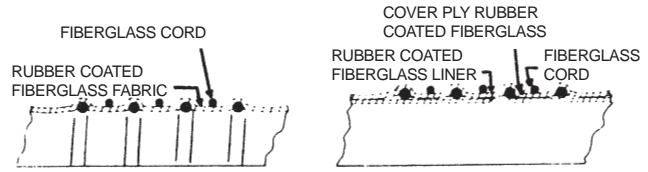

SEE TECH. DATA CATALOG FOR COMPLETE ENGINEERING INFORMATION

DUCT PRICES ARE PER FOOT—SOFT END PRICE EACH

DUCT PRICES ARE PER FOOT—SOFT END PRICE EACH

I.D. (In.)	SILFLEX				NEOFLEX			
	SSF	DSF	SSF CUFF	DSF CUFF	SNF	DNF	SNF CUFF	DNF CUFF
<b>1</b>	\$ 5.71*	\$ 8.68	\$ 7.16	\$ 8.10	\$ 6.69	\$ 8.46	\$ 5.84	\$ 6.24
<b>1¼</b>	6.16	9.78	7.23	8.30	6.87	8.78	5.96	6.36
<b>1½</b>	6.57*	10.99*	7.43	8.73	5.91	7.41	6.10	6.52
<b>1¾</b>	7.21	12.16	7.71	8.98	5.84	7.50	6.19	6.59
<b>2</b>	7.41*	13.29*	8.08	9.65	5.93*	7.98	6.29	7.35
<b>2¼</b>	8.12	14.60	8.54	10.18	6.02	8.48	6.46	7.98
<b>2½</b>	8.49*	15.83*	8.85	10.55	6.75*	8.98	6.64	8.03
<b>3</b>	9.06*	17.70*	9.34	10.85	7.36*	9.72*	6.83	8.12
<b>3½</b>	10.63*	20.44*	10.18	12.67	9.62	10.80	7.01	9.50
<b>4</b>	11.63*	22.38*	10.26	12.82	10.03*	11.77*	7.13	9.86
<b>4½</b>	13.75	24.77*	11.66	15.24	10.65	12.38	8.13	11.98
<b>5</b>	14.89*	27.32*	11.78	15.53	11.28*	13.03*	8.30	12.26
<b>5½</b>	17.56	30.01	11.93	15.67	11.88	15.33	8.48	12.46
<b>6</b>	21.62*	32.45*	12.41	16.31	11.94	15.49*	9.19	13.62
<b>6½</b>	29.11	35.99	13.24	17.47	13.37	17.24	10.34	15.24
<b>7</b>	33.11	38.20	14.18	18.67	13.99	17.64	10.47	15.58
<b>8</b>	38.88	45.07	15.12	19.97	16.86	23.17	11.83	16.24
<b>9</b>	41.83	49.59	16.24	21.36	18.24	24.92	12.16	16.64
<b>10</b>	43.47	54.01	17.34	22.87	19.44	26.56	12.38	16.97
<b>12</b>	50.37	62.84	18.52	25.38	23.10	32.09	13.99	19.59
<b>14</b>	55.99	70.31	20.01	28.20	29.95	43.93	15.83	22.13
<b>16</b>	61.61	82.83	21.84	31.30	38.04	57.79	17.88	25.01

**\*STOCK ITEMS**

**Standard Duct Length:** 11' or 20 Feet (11' Stock Length)  
20 Ft. Lengths available only for 2" and above

**Cuff Length:** Up to 5" I.D.—1½" Length  
Over 5" I.D.—2½" Length

**For other than 11 or 20 Foot Lengths:** Add 10% to foot price.

**Maximum Duct Length:** 20 Feet

**\*STOCK ITEMS**

**Standard Duct Length:** 10' or 20 Feet (10' Stock Length)  
20 Ft. Lengths available only for 2" and above

**Cuff Length:** Up to 5" I.D.—1½" Length  
Over 5" I.D.—2½" Length

**For other than 10 or 20 Foot Lengths:** Add 10% to foot price.

**Maximum Duct Length:** 20 Feet

ALL ITEMS SUBJECT TO MINIMUM LINE CHARGE.

SEE TERMS AND CONDITIONS—PAGE 12

PRICES SUBJECT TO CHANGE WITHOUT NOTICE.

**INDUSTRIAL DUCTING**

**TUFTEX®** TEMPERATURE RANGE -40°F to +250°F

**BASIC CONSTRUCTION TYPES**

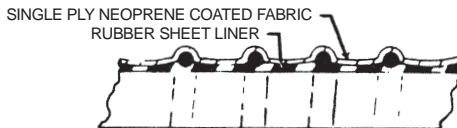

DUCT PRICES ARE PER FOOT—SOFT END PRICE EACH

SEE TECH. DATA CATALOG FOR COMPLETE ENGINEERING INFORMATION

I.D. (In.)	TUFTEX		MATERIAL HANDLING HOSE (MH)			
	TYPE CD	TYPE KD	MH1	MH2	MH3	LSH-CB
<b>1</b>	\$ 9.05	\$ 9.77	\$ —	\$ —	\$ —	\$ —
<b>1¼</b>	9.84	10.04	—	—	—	—
<b>1½</b>	9.93	10.32	—	—	—	—
<b>1¾</b>	10.00	10.94	—	—	—	—
<b>2</b>	10.32	11.51	22.77	32.79	37.80	—
<b>2¼</b>	10.71	12.02	—	—	—	—
<b>2½</b>	11.10	12.56	—	—	—	—
<b>2¾</b>	11.48	13.07	—	—	—	—
<b>3</b>	11.86*	13.58	28.20	40.25	45.54	—
<b>3½</b>	12.70*	15.26	—	—	—	—
<b>4</b>	13.56*	15.59	38.51	49.13	55.53	—
<b>4½</b>	15.59	17.42	—	—	—	—
<b>5</b>	16.41*	19.29	44.45	52.44	63.21	—
<b>5½</b>	18.23	21.56	—	—	—	—
<b>6</b>	18.69*	21.98	50.80	55.55	71.52	—
<b>6½</b>	20.09	23.53	—	—	—	—
<b>7</b>	21.49	25.12	52.11	61.51	84.85	—
<b>8</b>	23.79*	27.88	55.39	69.82	87.97	96.09
<b>10</b>	30.44	35.30	61.38	80.55	108.08	116.01
<b>12</b>	34.85*	40.82	84.80	89.40	128.05	131.87
<b>14</b>	42.68	49.66	88.23	116.76	159.40	167.37
<b>16</b>	46.80	57.90	123.84	140.95	201.52	205.47

**\*STOCK ITEMS**

**A. TUFTEX CD & KD**

- Standard Length:** Up to 2" I.D.—10 Ft.  
2" and over—20 Ft.
- Cuff Length:** Up to 6" I.D.—1½" Length  
6" I.D. and over—2½" Length

**B. MH**

- Standard Length:** 20 Ft.
  - List Prices Include Cuffs
- C.** Add 10% for other than standard length.  
**D.** For additional plies of rubber see page 8.

**LEAF SUCTION HOSE**

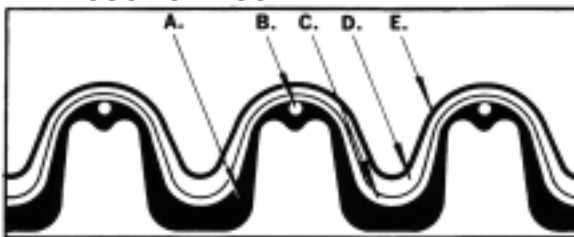

- A. Abrasion Resistant Tube
- B. Wire Helix
- C. Fabric Reinforcement
- D. Fabric Reinforcement
- E. Abrasion Resistant Cover

NOTE: For smooth-bore see MH<sub>2</sub> & MH<sub>3</sub> for construction and price.

ALL ITEMS SUBJECT TO MINIMUM LINE CHARGE.

**SEE TERMS AND CONDITIONS—PAGE 12**

PRICES SUBJECT TO CHANGE WITHOUT NOTICE.

## INDUSTRIAL DUCTING

### DIP COATINGS AND ADDITIONAL RUBBER PLIES

TEMPERATURE RANGE -20°F TO +250°F.

**NOTE: DIP COATING** (APPLICABLE TO ONLY FLEXKING) IS APPLIED AFTER DUCTING IS MANUFACTURED. DIP COATING WILL DECREASE DUCT I.D. APPROXIMATELY .015 TO .030 INCHES PER COAT. DIP COATING WILL DECREASE DUCT FLEXIBILITY.

**NOTE: RUBBER PLYS** APPLICABLE TO ONLY TUFTEX, TYPES CD & KD ARE MANUFACTURED INTO DUCTING. IT **WILL NOT** DECREASE I.D. AREA. RUBBER PLYS WILL DECREASE DUCT FLEXIBILITY.

I.D. (In.)	ADDITIONAL RUBBER PLYS					
	LINERS			COVERS		
	.015	.032	.062	.015	.032	.062
<b>1¼</b>	\$ 2.78	\$ 3.30	\$ 5.48	\$ 3.11	\$ 3.67	\$ 6.15
<b>1½</b>	3.04	3.61	5.63	3.42	4.10	6.51
<b>1¾</b>	3.30	3.95	6.05	3.67	4.39	6.76
<b>2</b>	3.58	4.25	6.37	4.10	4.73	7.11
<b>2¼</b>	3.95	4.48	6.61	4.39	5.04	7.40
<b>2½</b>	4.25	4.82	7.00	4.70	5.28	7.79
<b>3</b>	4.47	5.07	7.26	5.04	5.61	8.05
<b>3½</b>	4.82	5.47	7.62	5.28	5.89	8.34
<b>4</b>	5.07	5.63	7.82	5.61	6.15	8.69
<b>4½</b>	5.47	6.05	8.10	6.07	6.52	8.98
<b>5</b>	5.63	6.43	8.69	6.15	6.76	9.35
<b>5½</b>	6.03	6.61	9.29	6.51	7.11	9.54
<b>6</b>	6.61	7.62	10.18	7.11	8.34	10.25
<b>7</b>	7.26	8.05	11.74	8.05	8.98	12.37
<b>8</b>	7.82	8.69	12.01	9.25	10.25	12.70
<b>9</b>	8.70	9.67	13.15	10.25	11.29	13.55
<b>10</b>	9.54	11.07	14.78	11.40	12.32	15.98
<b>11</b>	11.13	12.66	15.93	12.66	13.73	16.88
<b>12</b>	12.32	14.18	17.50	13.89	14.89	18.10
<b>14</b>	15.53	17.36	20.27	17.52	18.57	21.39

**INDUSTRIAL DUCTING**

**CYCLONE®  
 BLOWER HOSE**

TEMPERATURE RANGE -40°F to +260°F

**BASIC CONSTRUCTION**

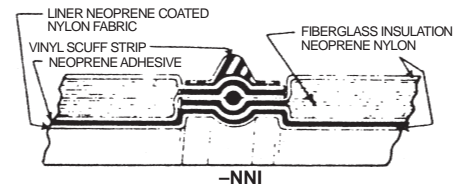
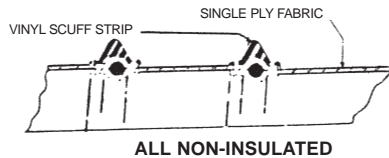

SEE TECHNICAL DATA CATALOG FOR COMPLETE ENGINEERING INFORMATION.

PRICES ARE PER FOOT (FRACTION FEET ARE PRICED AT NEXT WHOLE FOOT PRICE)

I.D. (In.)	UB	UBI	NNI-W	NCR
5	\$13.73	\$24.26	\$27.53	\$ 14.16
6	13.92	25.26	27.77	14.59
7	14.08	26.01	28.85	15.58
8	14.24	26.45	29.93	16.58
9	15.64	27.03	31.15	18.37
10	16.40	27.52	32.38	20.18
12	18.91	31.23	36.79	26.92
14	21.85	35.62	42.58	27.58
16	24.44	39.94	49.29	28.84
18	28.68	45.59	56.10	30.74
20	31.39	50.98	62.71	32.66
22	34.45	56.10	68.97	35.97
24	37.45	61.55	75.72	39.14
26	39.99	65.03	81.43	41.90
28	42.70	69.43	85.89	45.59
30	46.01	74.91	93.76	49.23

Larger Diameters are available price on request. (reduced wire pitch available on request.)

Standard Lengths—25 Feet. (For other than 25' lengths, add 10% to foot price.)

Longer lengths available upon request.

See Page 10 for Accessories.

ALL ITEMS SUBJECT TO MINIMUM LINE CHARGE.

SEE TERMS AND CONDITIONS—PAGE 12

PRICES SUBJECT TO CHANGE WITHOUT NOTICE.

**INDUSTRIAL DUCTING**

**ACCESSORIES**—PRICED EACH OR PER END. ALL TYPES OF CYCLONE®.

TYPE	DUCT INSIDE DIAMETER IN INCHES										
	5	6	8	10	12	14	16	18	20	22	24
SOFT CUFFS (1)	\$13.74	\$14.07	\$14.63	\$20.14	\$25.56	\$41.92	\$46.62	\$55.52	\$75.06	\$82.03	\$86.22
QUICK COUPLINGS FLAT BAND	CONSULT CHANUTE FOR PRICE										
QUICK COUPLINGS WIRE RING	CONSULT CHANUTE FOR PRICE										
HANGAR HOOKS	CONSULT CHANUTE FOR PRICE										
GROMMETS	CONSULT CHANUTE FOR PRICE										
BELT LOOPS	CONSULT CHANUTE FOR PRICE										
TAPERED CUFFS	CONSULT CHANUTE FOR PRICE										
STRAPS WITH BUCKLE	CONSULT CHANUTE FOR PRICE										

**(1) Cuff Lengths:** 4" through 10" I.D.—3" Length; Over 10" I.D.—4" Length (Unless otherwise stated).

**CYCLONE ACCESSORIES**

**Belt Loops**—When repeated loosening and tightening of clamps is expected, belt loops should be permanently attached to the ducting's soft cuff. The loops are two piles of the same material as the soft cuff.

**Hanger Hooks** permit suspension of ducting from an overhead travel wire. Hooks are made of non-corrosive metal and are permanently attached to ducting.

**Coupling:**

1. Flatband spring steel couplings are available.
2. Wire rings are also available and more economical than flat band couplings.

**Connecting to blower**—One end of a single length can be supplied with a soft cuff, which can be easily slipped over and clamped to the fan or blower collar.

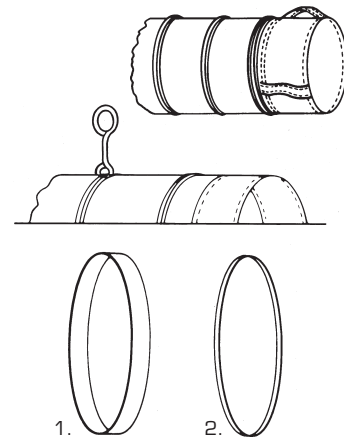

To couple: flat band or wire ring coupling.



INSERT  
AND  
TWIST



PULL BACK  
AND  
LOCK

To Disconnect: Simply reverse the procedure shown above.

ALL ITEMS SUBJECT TO MINIMUM LINE CHARGE.

**SEE TERMS AND CONDITIONS—PAGE 12**

PRICES SUBJECT TO CHANGE WITHOUT NOTICE.

**INDUSTRIAL DUCTING****CHANUTE OPERATIONS INDUSTRIAL DUCTING****TERMS:** Net 30 days.**FREIGHT:** F.O.B. Shipping Point. No Freight Allowed.**MINIMUM CHARGES:** Minimum order charge \$100.00 Net. Minimum line charge \$20.00 Net. **NOTE:** set up charge of \$75.00 Net will be applied to any item that is shown as non-stock and has a net order value of less than \$750.00. There will be no set up charge on an item that values more than \$750.00.**TERMS AND CONDITIONS OF SALE:** See Page 12.**STANDARD TOLERANCES**

The following tolerances apply to all Thermoid industrial ducting, unless otherwise stated or produced to a specific customer's blueprint.

**Note:** Ducting and hose frequently "sets" shorter or longer if sorted or shipped in coiled or vertical positions. Most hose will return to the prescribed length if stretched a few times by hand. Rubber-lined or cotton hose will usually shrink approximately 1½ to 2½% in over-all length because of the nature of the materials.**PRODUCT SERIES:****Neoflex®, Silflex®** and related products within these series.**A. Random Length (Plain Ends)**

1. I.D. (inside diameter)  $\pm .03"$  ( $\frac{1}{32}"$ )
2. O.A.L. (overall length)  $\pm \frac{1}{4}"$  per foot

**B. Cut To Length—Cuffed (soft end) Item**

1. I.D. (inside diameter)  $\pm .03"$  ( $\frac{1}{32}"$ )
2. O.A.L. (overall length)
  - (a) under 18" O.A.L.  $\pm \frac{1}{8}"$
  - (b) 18" O.A.L. and longer  $\pm \frac{1}{8}"$  per foot of length
3. Soft ends (cuffs)
  - $+\frac{1}{4}"$
  - $-\frac{1}{8}"$

**PRODUCT SERIES:****Tuftex®, FlexKing®, Ultraflex®** and related products within the scope of these series.**A. Random Length(s) No Cuffed Ends**

- |   |   |
|---|---|
| <ol style="list-style-type: none"> <li>1. Tuftex I.D. (inside diameter) <math>\pm .03"</math> (<math>\frac{1}{32}"</math>)</li> <li>FlexKing I.D. (inside diameter) up to 8" <math>-0"</math><br/><math>+ .06"</math><br/>over 8" <math>-0"</math><br/><math>+ .08"</math></li> </ol> | <ol style="list-style-type: none"> <li>2. O.A.L. (overall length) <math>\pm \frac{1}{4}"</math> per foot length<br/><math>-\frac{1}{8}"</math> per foot length</li> </ol> |
|---|---|

**Note:** These product series when coiled, and stored or shipped in this manner, will frequently "set" or tend to remain in that position. They also have a tendency to shrink 2 to 3% in overall length due to the nature of relative light walled rubber, cotton or nylon. Duct/hose can be installed to nominal length.**B. Cuffed (soft end) Items**

- |   |   |
|---|---|
| <ol style="list-style-type: none"> <li>1. Tuftex I.D. (inside diameter) <math>\pm .03"</math> (<math>\frac{1}{32}"</math>)</li> <li>FlexKing I.D. (inside diameter) up to 8" <math>-0"</math><br/><math>+ .06"</math><br/>over 8" <math>-0"</math><br/><math>+ .08"</math></li> </ol> | <ol style="list-style-type: none"> <li>2. O.A.L. (overall length) <math>\pm \frac{1}{4}"</math> per foot length</li> <li>3. Cuff (soft end) length <math>+\frac{1}{4}"</math><br/><math>-\frac{1}{8}"</math></li> </ol> |
|---|---|

**CYCLONE SERIES:****A. Random (duct excluding cuffs)**

1. I.D.  $+\frac{1}{4}"$   
 $-\frac{1}{8}"$
2. O.A.L.  $+\frac{1}{2}"$  per foot  
 $-\frac{1}{8}"$  per foot

**B. Cuff(s) soft end(s)**

1. I.D.  $+\frac{1}{4}"$   
 $-0"$
2. Cuff lengths  $+1"$   
 $-\frac{1}{2}"$

**ENTIRE AGREEMENT**

The parties agree that there are no understandings, agreements or representations, express or implied, not specified herein, respecting this offer or sale, and that this instrument contains the entire agreement between Seller and Buyer. No prior waiver, course of prior dealing or usage of the trade shall be relevant to supplement or to explain terms used in this agreement.

**CONTROLLING TERMS**

All sales are expressly limited to, and the rights and liabilities of the parties shall be governed exclusively by, the terms and conditions herein. In the event any purchase order or offer from Buyer states terms additional to or different from those set forth herein, this document shall be deemed a notice of objection to such additional or different terms and a rejection thereof. Any acknowledgment or shipment of product by Seller to Buyer subsequent to Seller's receipt of a purchase order or offer from Buyer shall not be deemed to be an acceptance by Seller of an offer to contract on the basis of any Buyer's terms and conditions. Receipt and acceptance by Buyer of products shall be conclusive evidence of Buyer's acceptance of the terms and conditions set forth herein as the sole controlling terms and conditions of the contract between Seller and Buyer. Stenographic and clerical errors by Seller are subject to correction.

**ACCEPTANCE OF ORDERS**

Seller possesses the exclusive right to accept or refuse any and all orders. No bid, offer, or quotation shall be valid or binding upon Seller, and no order shall be accepted and no sale shall be final, until such bid, offer, quotation, order or sale shall be acknowledged in writing by Seller. See price pages for minimum order amount.

**PRICES**

All prices are subject to change without notice and shall be adjusted to the Seller's prices in effect on the date of shipment. Prices reflect standard packaging for domestic shipment only. All prices are in U.S. Dollars. All tooling and equipment Seller produces or acquires for purposes of filling this order shall remain property of Seller. All intellectual property associated with the products shall remain the sole property of Seller.

**DELIVERY**

Delivery dates are estimates and not a guaranty of a particular day of delivery and are based on the prompt receipt of all necessary information from the Buyer. Seller shall not be liable for failure or delay in shipping goods hereunder if such failure or delay is due to an act of God, fire, flood, war, labor difficulties, accident, strikes, lockouts, civil disorders, governmental priorities or embargoes, inability or difficulty in obtaining raw materials or supplies at customary terms and prices or any other causes or failure of presumed conditions of any kind whatsoever which are either beyond the reasonable control of the Seller or which would make impracticable the fulfillment of Seller's obligations hereunder. Buyer shall not refuse to accept deliveries so delayed. Seller shall be compensated for any and all extra costs and expenses occasioned by delays attributable to Buyer.

**TRANSPORTATION AND RISK OF LOSS**

All shipments are freight collect unless eligible for a freight allowance expressly set forth in current price sheets or on the face hereof. Seller reserves the right to select the method and type of transportation. If a method of transportation other than that selected by Seller is requested by Buyer, excess packing, shipping and transportation charges resulting from compliance with Buyer's request shall be for the Buyer's account. All shipments are F.O.B. point of shipment and risk of loss shall pass to Buyer after products are delivered to carrier. Claims for damage or loss in transit must be filed by Buyer against the carrier.

**CANCELLATION OR MODIFICATION**

Buyer may not cancel or modify any order, either in whole or in part, without Seller's prior written consent and then only upon payment to Seller for all applicable costs incurred by Seller, including, without limitation, costs of materials, labor, equipment and supplies, and for lost profits on cancelled or modified orders. Order changes or additions received after original order has been processed will be treated as a new order.

**TAXES**

Any taxes which Seller may be required to pay or collect with respect to the sale, delivery or storage of the products, including taxes upon or measured by the receipts from the sales thereof, shall be for the account of Buyer who shall promptly pay the amount thereof to Seller upon demand, or in lieu thereof, furnish Seller with a tax exemption certificate acceptable to the taxing authorities.

**WARRANTY AND DISCLAIMER**

Seller warrants that its products shall be free from defects in material and workmanship under normal use and service for a period of 12 months from date of shipment. On equipment and materials furnished by Seller but manufactured by others, Buyer shall accept in lieu of any liability or guarantees on the part of Seller, the benefits of guarantees as are obtained by Seller from such manufacturers or vendors. SELLER MAKES NO WARRANTY OF MERCHANTABILITY OR FITNESS FOR A PARTICULAR PURPOSE OR ANY OTHER WARRANTY, EXPRESS OR IMPLIED, EXCEPT AS IS EXPRESSLY SET FORTH HEREIN. Failure by Buyer to object to or reject products or materials delivered hereunder, in writing within 30 days from the date of shipment of the products or materials, shall constitute an acceptance and waiver by Buyer of all claims hereunder on account of alleged errors, shortages, defective workmanship or material, breach of warranty or otherwise, discoverable upon inspection by Buyer.

**LIMITATION OF LIABILITY**

Buyer's exclusive remedy on any claim of any kind for any loss or damage arising out of, connected with, or resulting from this contract, or from the performance or breach thereof, or from the design, manufacture, sale, delivery, resale, or repair or use of any products covered by or furnished under the contract, including but not limited to any claim for breach of warranty, negligence, strict liability or other tort, shall be the repair or replacement, F.O.B. Seller's factory, as Seller may elect, of the product or part thereof giving rise to such claim, except that Seller's liability for such repair or replacement shall in no event exceed the contract price allocable to the product or part thereof which give rise to the claim. SELLER SHALL IN NO EVENT BE LIABLE FOR DIRECT, INDIRECT, INCIDENTAL OR CONSEQUENTIAL DAMAGES.

**RETURN OF MATERIAL**

Seller's permission must be obtained in writing before any products are returned to it by Buyer. If products are returned without such permission, Buyer authorizes Seller, in addition to such other remedies as it may have, to hold the returned products at Buyer's sole risk and expense. All returns must be freight prepaid by Buyer. Seller will in no event accept the return of any product that upon return is in the opinion of Seller altered, damaged, used, or in other than first class salable condition.

**INDEMNITY**

Buyer agrees to indemnify, defend and hold harmless Seller from any claims, loss or damages arising out of or related to Seller's compliance with Buyer's designs, specifications or instructions in the furnishing of products to Buyer, whether based on infringement of patents, copyrights, trademarks or other rights of others, breach of warranty, negligence, strict liability or other tort.

**PAYMENT**

All invoices are due net 30 days from date of invoice unless otherwise specified by Seller. If at any time Seller deems itself insecure from any cause whatsoever, including but not limited to adverse changes in Buyer's financial condition or impairment of Buyer's credit, Seller may in its sole discretion stop delivery of goods, require advance payment for goods, and/or declare immediately due all indebtedness owed to Seller including amounts due hereunder. Payments not made when due shall bear interest at the prime rate plus 5% per annum or, if lower, the highest rate legally permissible, until paid. Credit balances will be applied against future purchases only and must be claimed within one year of creation or are waived.

**GOVERNING LAW AND ARBITRATION**

Any dealings or contract between the parties shall be governed by and construed in accordance with the law of the state of Ohio, excluding its choice of law provisions. Buyer and Seller agree that any action, suit or proceeding arising hereunder or related hereto may be brought in any state or federal court of competent jurisdiction sitting in the State of Ohio and each party submits to the jurisdiction of such courts. Either Buyer or Seller may elect to have any controversy arising under or in any way related to the subject matter hereof decided by arbitration by a single disinterested arbitrator in Columbus, Ohio, U.S.A., in accordance with the commercial rules of the American Arbitration Association then obtaining. The fee for the arbitrator shall be shared equally by the parties. Each party shall bear its own costs and expenses, including attorneys fees.

Revised 06/01/2008

Reprinted 05/2011

**CAUTION: USE OF DAMAGED HOSE/DUCTING OR MISAPPLICATION MAY RESULT IN PROPERTY DAMAGE OR SERIOUS PERSONAL INJURY. INSPECT REGULARLY.**